

**Pilot Study  
Not valid for  
execution**

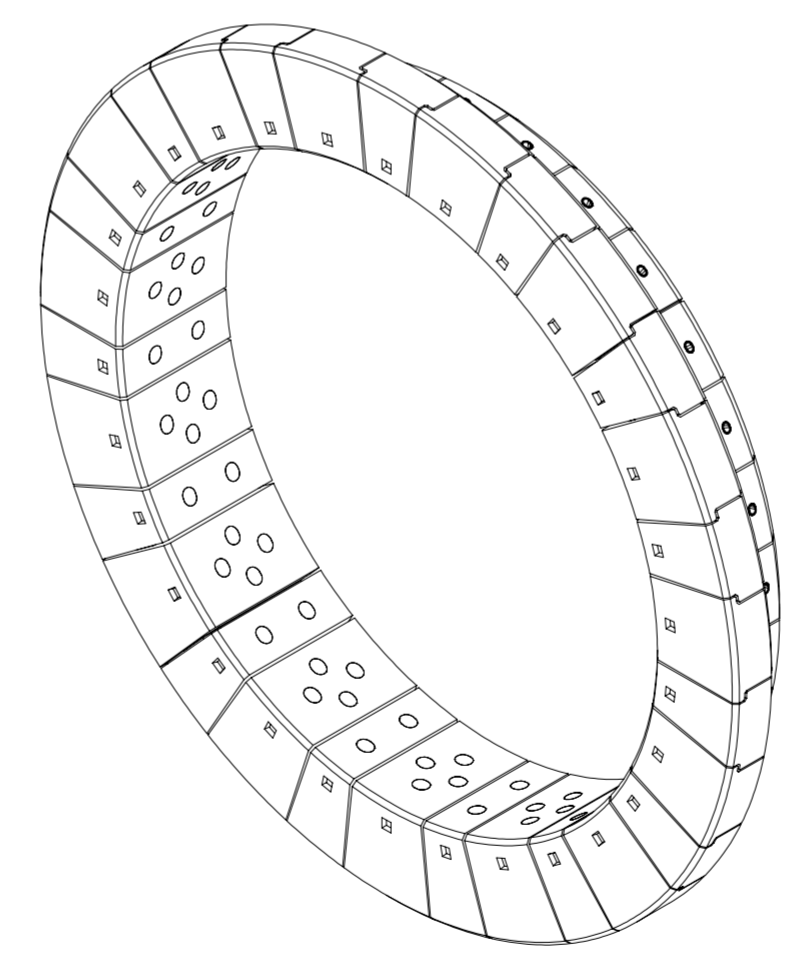
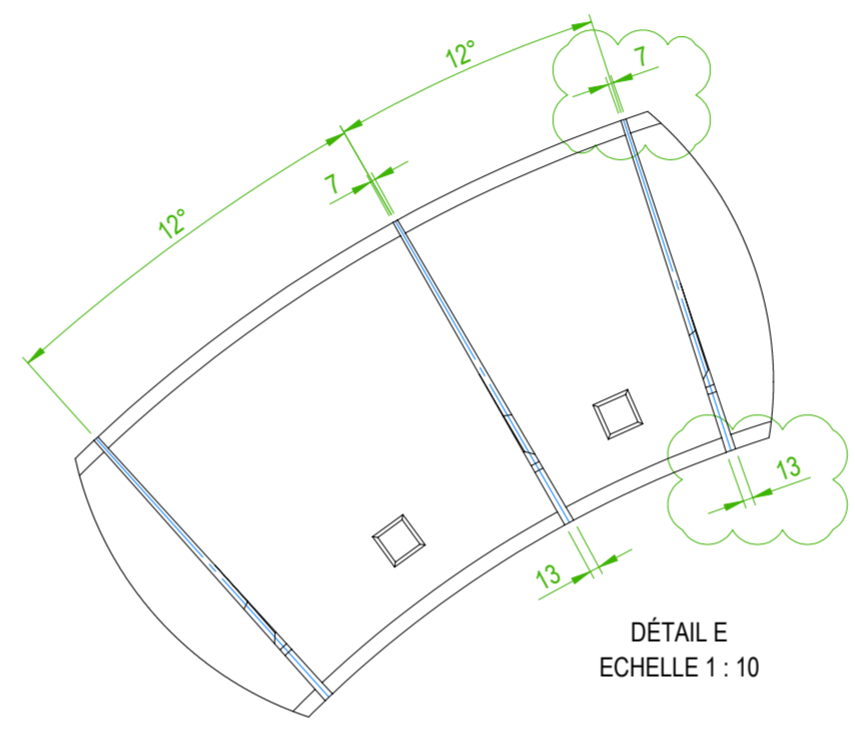
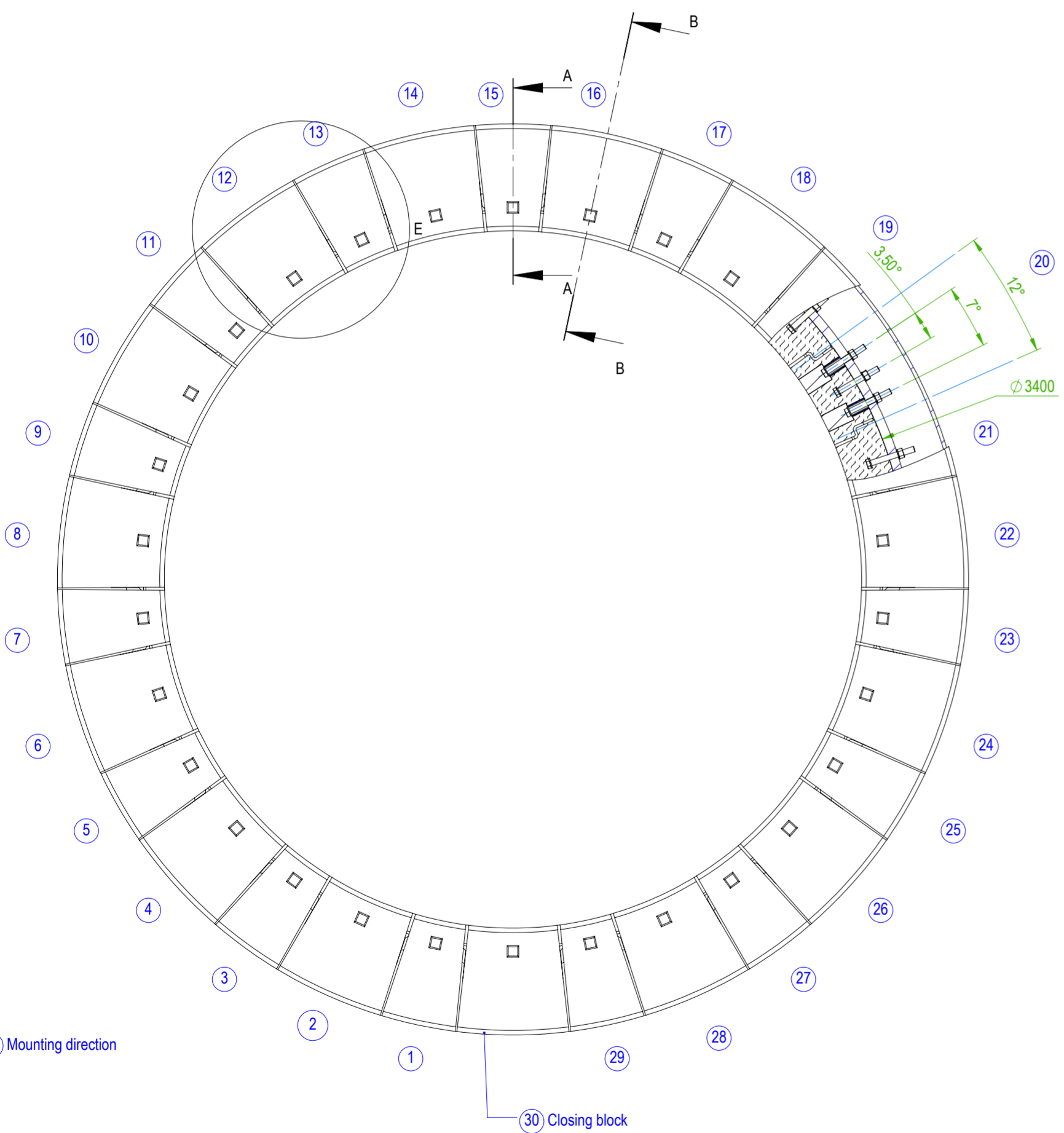
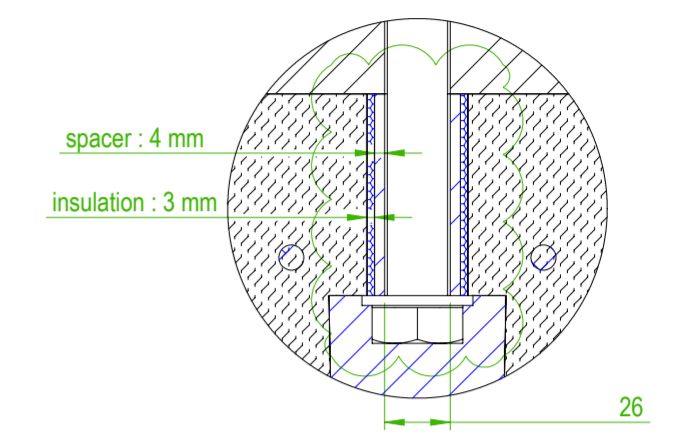
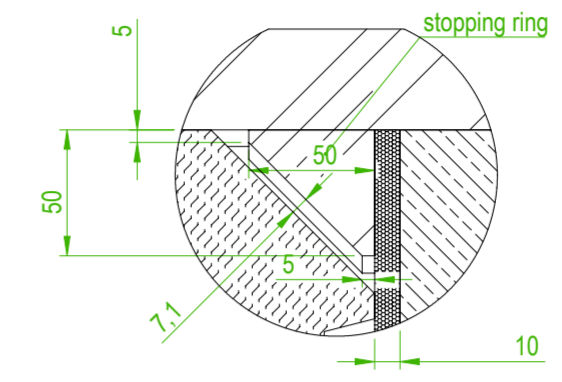
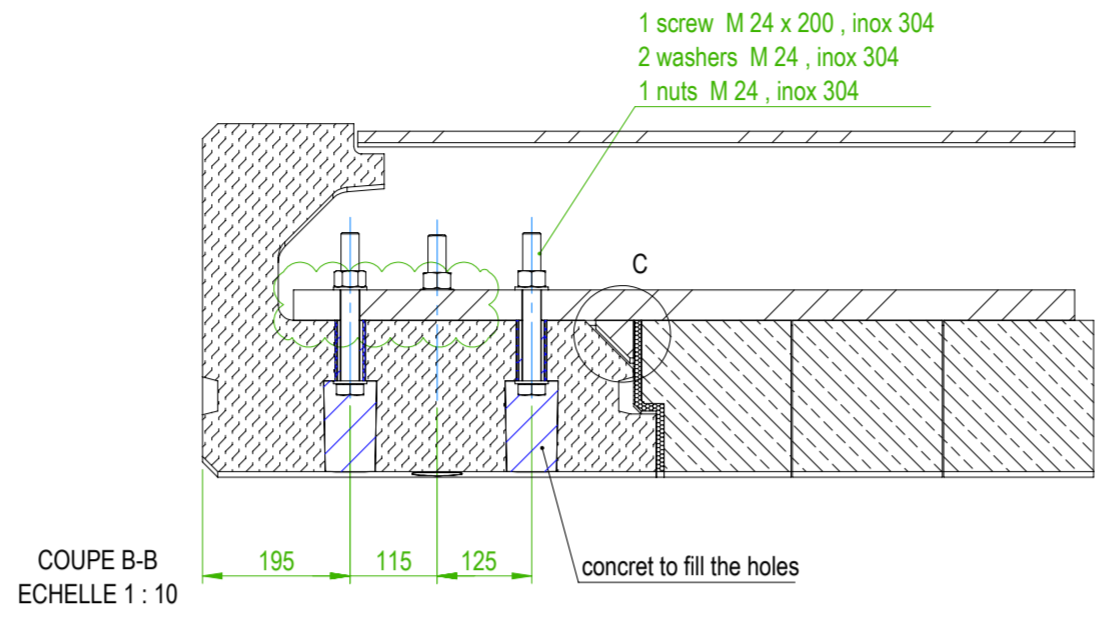
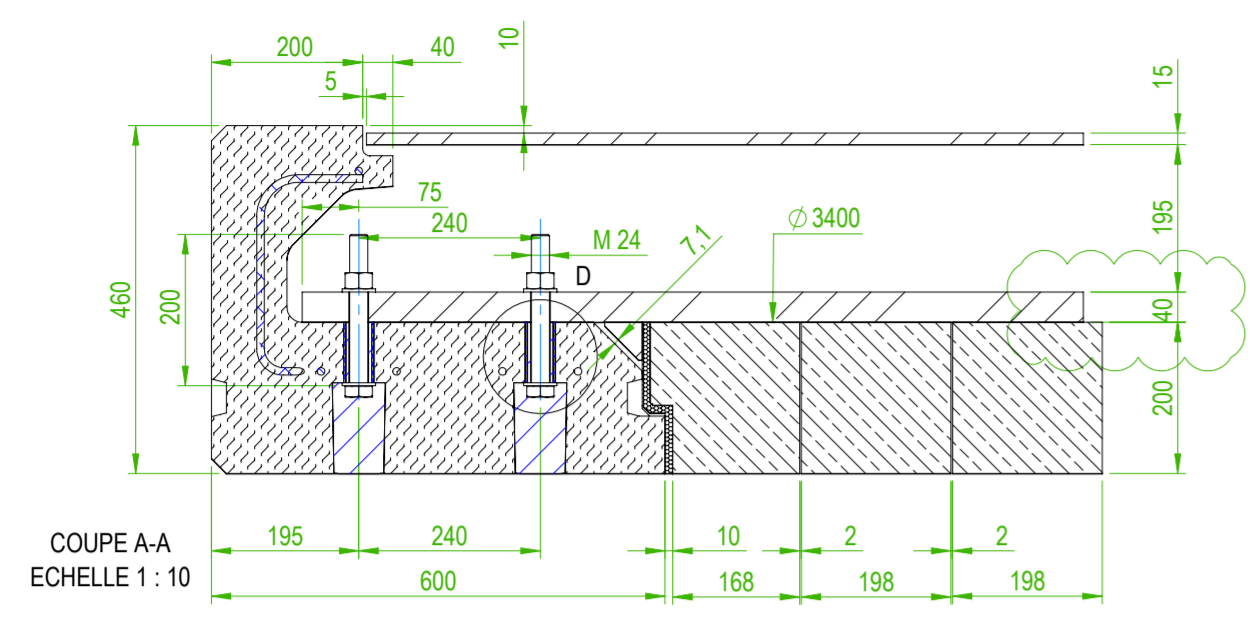

DÉTAIL C  
ECHELLE 1 : 3

DÉTAIL D  
ECHELLE 1 : 3

DÉTAIL E  
ECHELLE 1 : 10

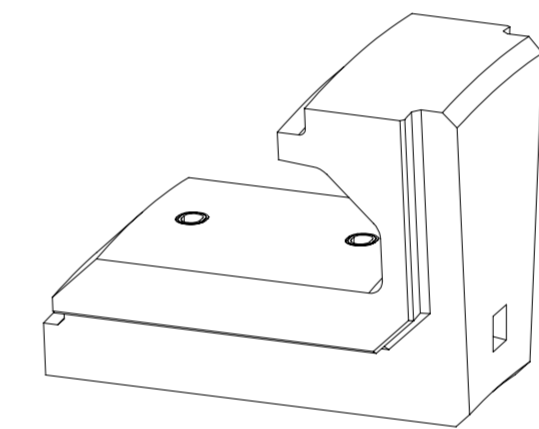

Female block, drawing 14-151-013  
Fastening :  
2 screw M 24 x 200, inox 304  
4 washers M 24, inox 304  
2 nuts M 24, inox 304

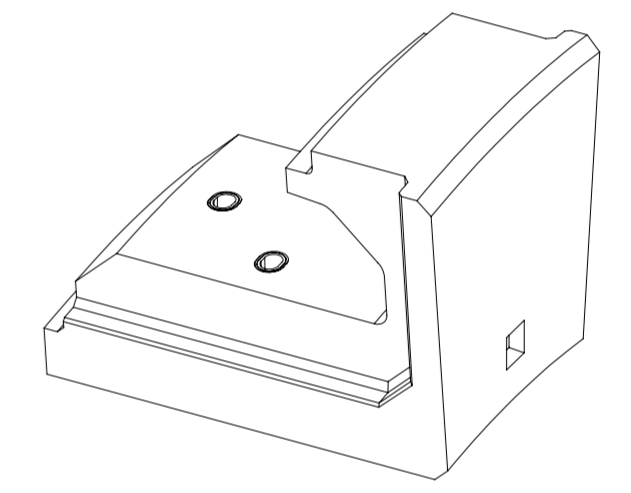

Male block, drawing 14-151-014  
Fastening :  
4 screw M 24 x 200, inox 304  
8 washers M 24, inox 304  
4 nuts M 24, inox 304

Revision	Nature of the modification	Date	Drawn by	Approved by
Révision 7	Modification of the gap between blocks	22/10/2019	SED	
Révision 6	Modification of the metallic shell	31/10/2018	NG	
Révision 5	New concret, reinforcement of screw passage	23/10/2018	NG	MB
Révision 4	New design	08/01/2018	BB	MB
Révision 3	Implantation 6 blocks TRB into customer segment	09/01/2017	NG	MB
Révision 2	Allonged version of the revision 1	30/10/2014	NG	
Révision 1	Modification of some details	24/10/2014	NG	
Revision 0	First Emission	20/10/2014	NG	

All the dimensions are tolerated at +/- 5 mm for refractories areas unless noted otherwise in the drawing.  
All the dimensions are tolerated at +/- 2 mm for sheet metal unless noted otherwise in the drawing.

Manufacturing consignes	Customer agreement
Clamp lifting Concret to fill the screws holes Closing block with lifting sleeve Rd12	
	date and signature

**Subject :** Nosinging Ø3400  
**Assembly drawing**

**Customer :** ODRA

**TRB FRANCE**  
Établissement principal & Usine  
B.P.9 - 62152 Nesles - FRANCE  
Tél. : +33 (0)3.21.99.54.54  
Fax. : +33 (0)3.21.99.54.50  
E-mail : contactnesles@trb.fr

Date: 22/10/2019  
Drawn by: SED  
Approved by:

Scale: 1:20  
Format: A2  
Revision: 7

N°Plan : 14-151-001

thk. min  
thk

ALL WELD : A = 0.5 x thk. min  
TOUTES SoudURES : A = 0.5 x Ep. min  
(IF NOT SPECIFIED OTHERWISE)  
(SAUF INDICATION CONTRAIRE)

Ce plan est et reste notre propriété et ne peut être copié, reproduit ou communiqué à des tiers sans notre accord écrit.  
Diese Zeichnung ist unser Eigentum und darf ohne unsere Zustimmung nicht vervielfältigt oder weitergegeben werden.  
This drawing is and remains our property. It is forbidden to copy, reproduce or to communicate it to third parties without our written consent.