

**Pilot Study
Not valid for
execution**

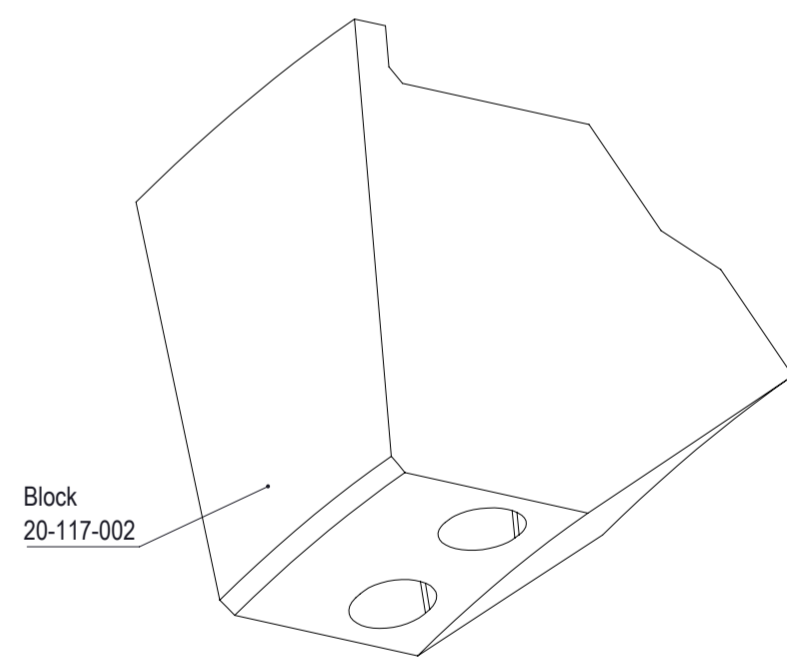

Drawing with dimensions not valid for execution

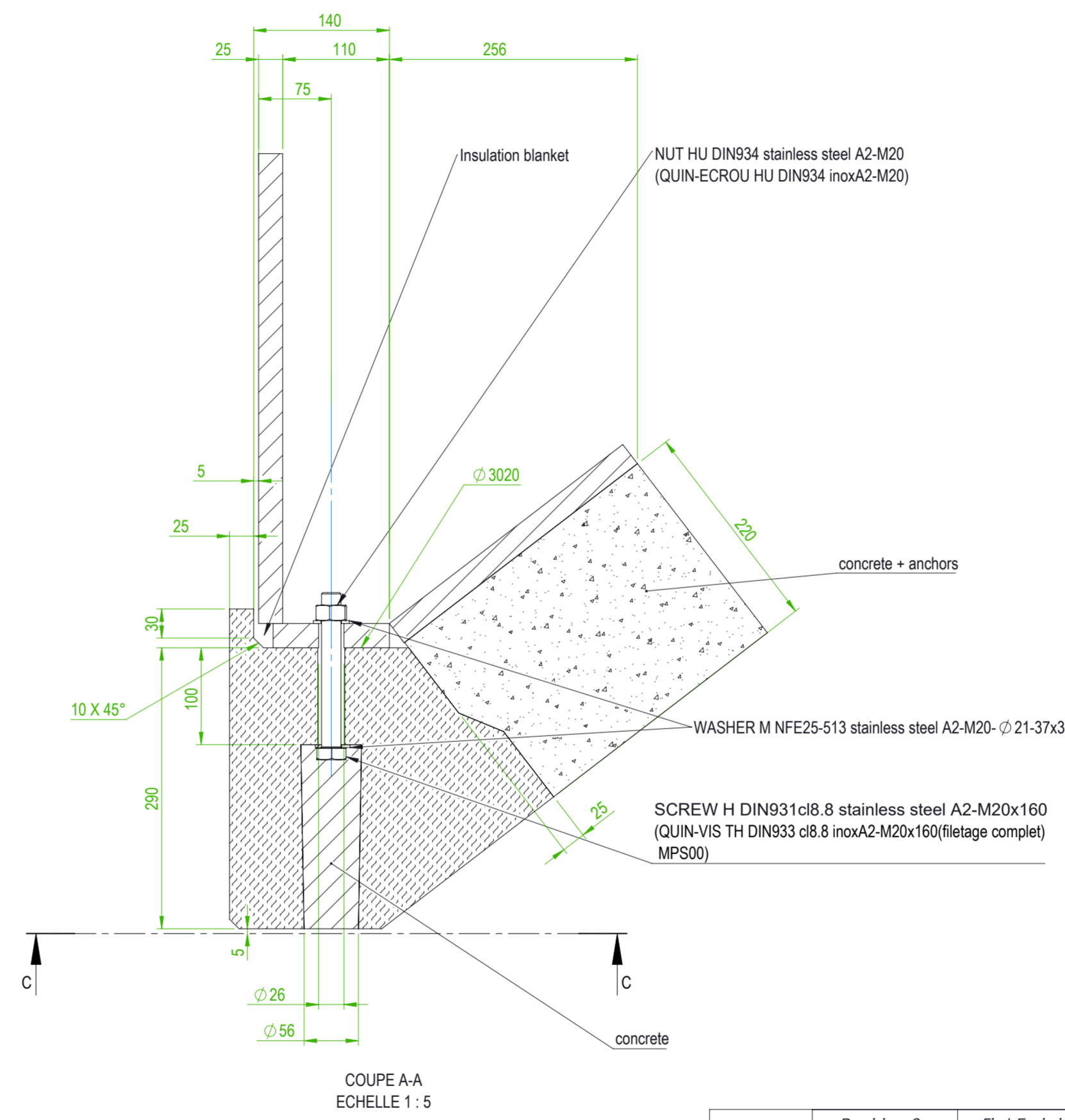
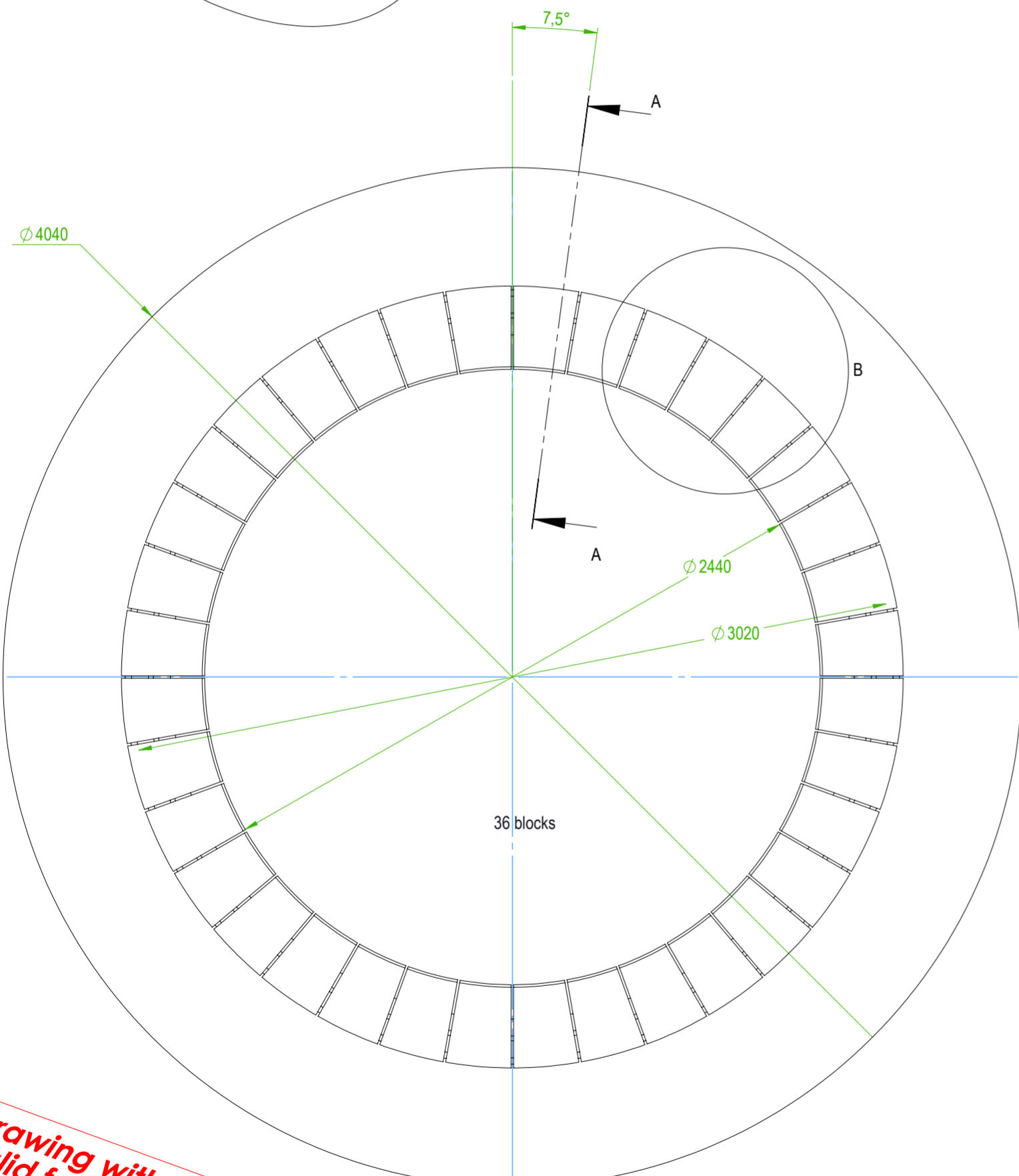
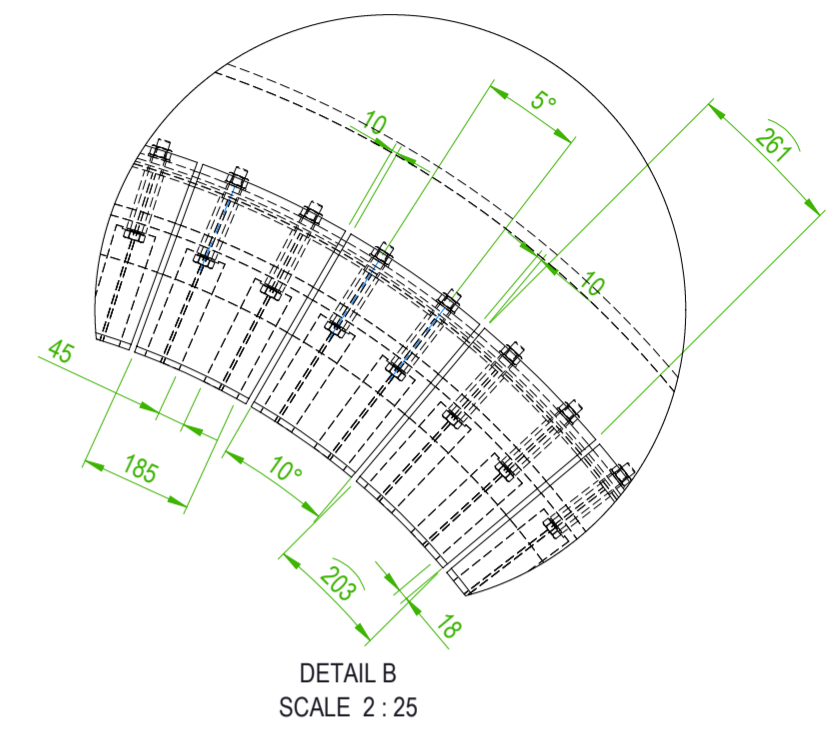
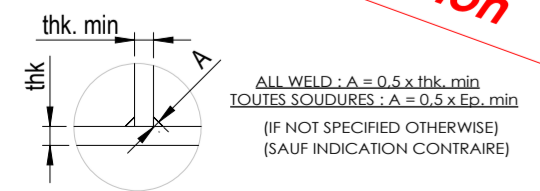

Ce plan est et reste notre propriété et ne peut être copié, reproduit ou communiqué à des tiers sans notre accord écrit.
Diese Zeichnung ist unser Eigentum und darf ohne unsere Zustimmung nicht vervielfältigt oder weitergegeben werden.
This drawing is and remains our property. It is forbidden to copy, reproduce or to communicate it to third parties without our written consent.

Manufacturing consignes	Customer agreement
	date and signature

All the dimensions are tolerated at +/- 5 mm.
for refractories areas unless noted otherwise in the drawing.
All the dimensions are tolerated at +/- 2 mm
for sheet metal unless noted otherwise in the drawing.

Revision 0	First Emission	01/09/2020	LF	
Revision	Nature of the modification	Date	Drawn by	Approved by
Subject : Cone d'entrée		Date:	01/09/2020	
Customer : ODRA OPOLE		Drawn by :	LF	
TRB FRANCE Établissement principal & Usine B.P.9 - 62152 Nesles - FRANCE Tél. : +33 (0)3.21.99.54.54 Fax. : +33 (0)3.21.99.54.50 E-mail : contactnesles@trb.fr		Approved by :		
N°Plan : 20-117-001		Scale: 1:20	Format	Revision
			A2	0